

REVISIONS			
REV	DESCRIPTION	DATE	APPROVED
B	Changed Description QBI-00 to QBI-00/02 PER ECO 13-17058	091813	DS
C	ADDED WEIGHT PER ECO 13-17318	103113	L. PITZELE
D	MOVED OUTPUT TERMINAL BLOCK TO MATCH UPDATED PCB; UPDATED DRAWING TITLE PER ECO 13-17526	122013	L. PITZELE

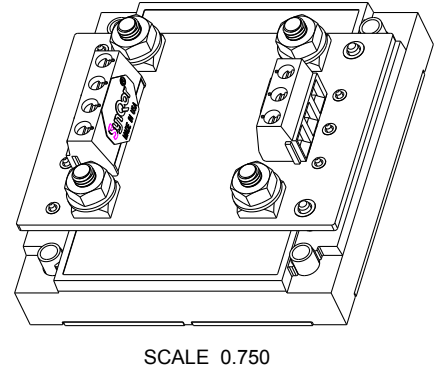
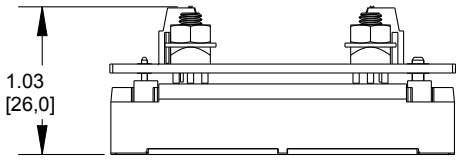
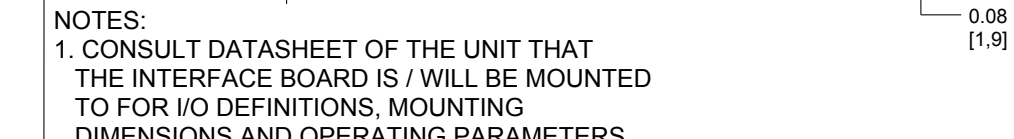
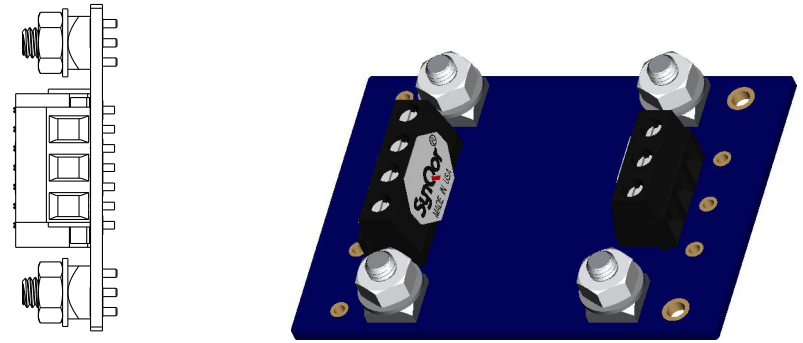

- NOTES:**
- CONSULT DATASHEET OF THE UNIT THAT THE INTERFACE BOARD IS / WILL BE MOUNTED TO FOR I/O DEFINITIONS, MOUNTING DIMENSIONS AND OPERATING PARAMETERS.
 - ALL DIMENSIONS IN INCHES (MM)
TOLERANCES: X.XX ± .02 IN. (X.X ± .5mm)
X.XXX ± .010 IN. (X.XX ± .25mm)
 - TERMINALS 1, 3, 4, 8: M4 SCREW POST, MAX TORQUE 6 IN-LB (.7 Nm).
 - TERMINAL BLOCKS: WIRE SIZE 16-30 AWG, 13.5A MAX CURRENT PER TERMINAL, MAX TORQUE 4 IN-LB (.5 Nm)
 - FITS NORMAL, NON-THREADED AND FLANGED HALF BRICKS
 - ADAPTOR WEIGHT: 1.06 oz (30 g)

TOLERANCES:
Unless otherwise specified:
All dimensions in inches
.X +/- .025
.XX +/- .010
.XXX +/- .005
Angles +/- 1°

THIRD ANGLE PROJECTION

THIS DRAWING IS THE PROPERTY OF SYNQOR INC. It is not to be reproduced or copied, in whole or in part, or used for furnishing information to others, or for any purpose detrimental to the interests of SynQor. The information shown herein may be protected by patents owned or controlled by SynQor.

SynQor 155 Swanson Road
Boxborough, MA 01719

**HBI-00 CONV. INTERFACE ASSY.
THROUGH HOLE MOUNTING**

SOURCE: PRO/E 020-0000249

SIZE A	DATE 122013	DWG. NO. 020-0000249	REV D
SCALE: 1.000	DRAWN: LDP	CHECK:	SHEET 1 of 1