

REVISIONS			
REV	DESCRIPTION	DATE	APPROVED
C	FIXED CONNECTOR PER ECO #12-15099	05/23/12	S SHAW
D	CHANGED TITLE PER ECO #12-15212	06/28/12	J.Tichy
E	ADDED WEIGHT PER ECO 13-17280	10/21/13	DS

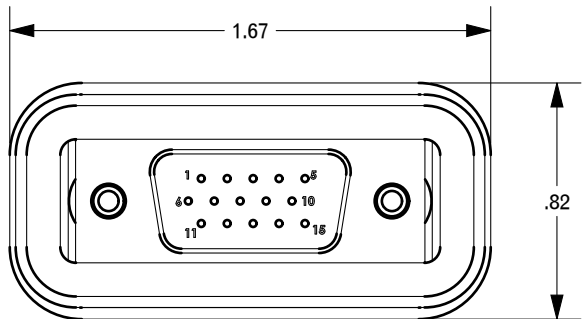
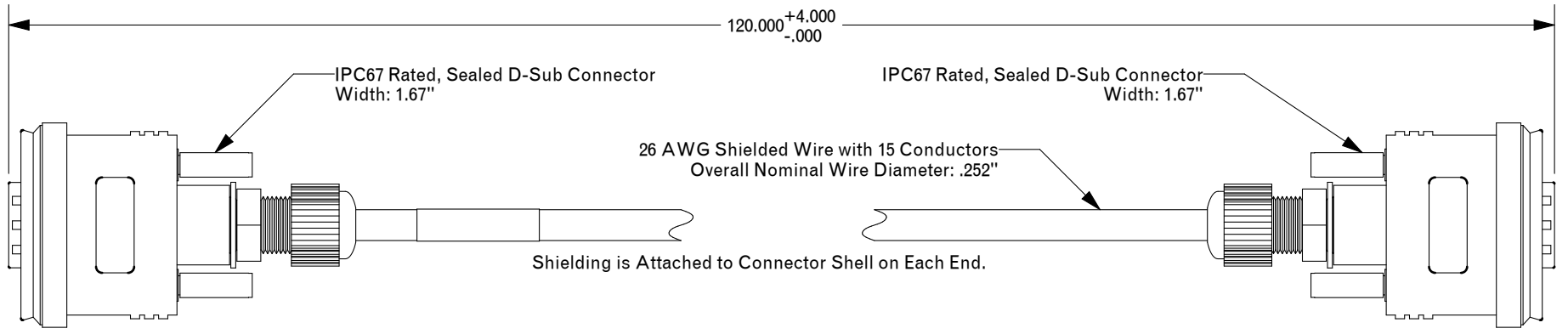

DB15 Male

SCALE 1.500

TOLERANCES:
 Unless otherwise specified:
 All dimensions in inches
 .X +/- .025
 .XX +/- .010
 .XXX +/- .005
 Angles +/- 1°

THIRD ANGLE PROJECTION

THIS DRAWING IS THE PROPERTY OF SYNQOR INC.
 It is not to be reproduced or copied, in whole or in part, or used for furnishing information to others, or for any purpose detrimental to the interests of SynQor. The information shown herein may be protected by patents owned or controlled by SynQor,

SynQor 155 Swanson Road
 Boxborough, MA 01719

UPS User I/O Cable 15M-15M

SOURCE: PRO/E USER_I-O_CABLE_15M-15M

SIZE	DATE	DWG. NO.	REV
A	Jun-28-12	SYN-9305	E

SCALE: 0.750 DRAWN: SJS CHECK: SHEET 1 of 1

- Notes:
1. REFERENCE SYNQOR SPECIFICATION: 705-1000055
 2. WEIGHT: .70lb [.318kg]