

PASSIVE EMI FILTER

-80 to +80V
Input

20A
Output Current

32mΩ @ 100°C
Max DC Resistance

>80dB @ 250kHz
Differential Attenuation

FULL POWER OPERATION: -40°C TO +100°C

The InQor® series of EMI filters brings SynQor's field proven technology and manufacturing expertise to the industrial power applications marketplace. SynQor's innovative packaging approach ensures survivability in the most hostile environments. Compatible with the industry standard format, these filters have high differential-mode and common-mode attenuation, low DC resistance, and a stabilizing bulk capacitor resistor. They follow conservative component derating guidelines and they are designed and manufactured to the highest standards.

InQor®



IQ080PFQTx20 Module

Operational Features

- 40°C to +100°C Operation
- ±80V Input Voltage Range; ±100V Transient (1s)
- 20A output current
- Very low DC resistance
- >80dB differential-mode attenuation at 250kHz
- >36dB common-mode attenuation at 250kHz
- Stabilizing bulk capacitor and damping resistor included
- All capacitors are X7R multi-layer ceramic

Mechanical Features

- Size: 1.54" x 2.39" x 0.50" (39.0 x 60.6 x 12.7 mm)
- Total weight: 3.53oz (100g)

In-Line Manufacturing Process

- AS9100 and ISO 9001:2000 certified facility
- Full component traceability

CONTENTS

	Page No.
Fundamental Circuit Diagram	2
Typical Connection Diagram	2
IQ080PFQTx20 Electrical Characteristics	3
BASIC OPERATION AND FEATURES	4
Standards & Qualification Testing	5
Mechanical Drawing	6
QTV Mechanical Drawing	7
Ordering Information	8

Fundamental Circuit Diagram

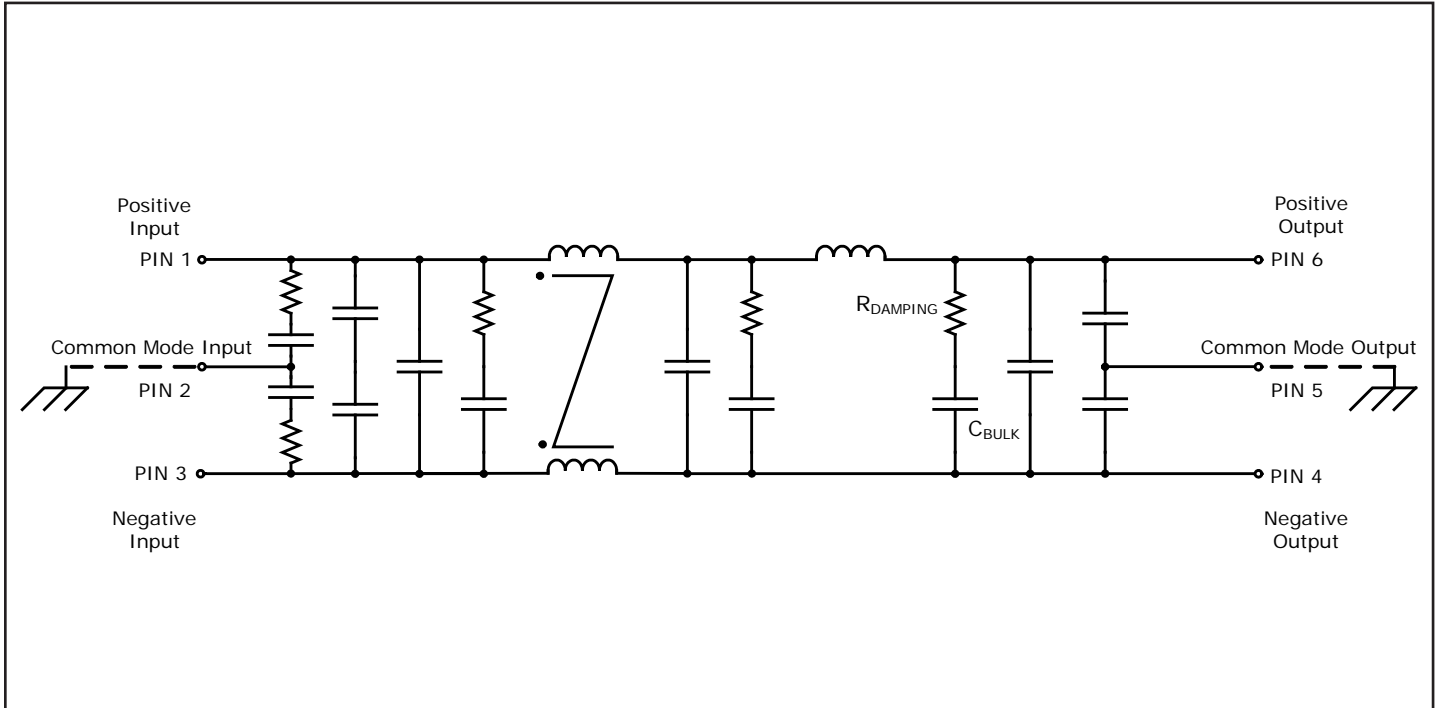

Typical Connection Diagram

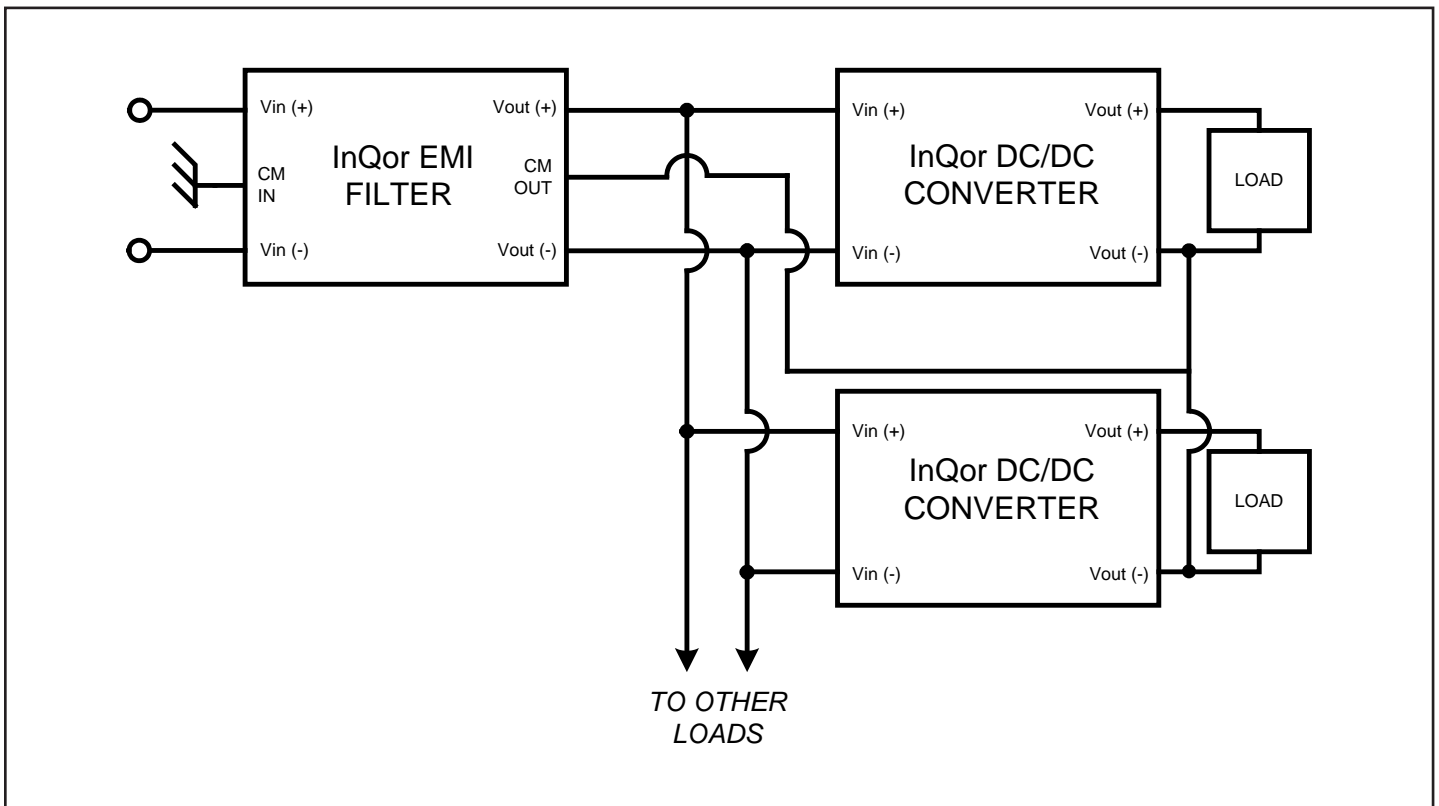

IQ080PFQTx20 Electrical Characteristics

|Vin| ≤ 80V, |Iout| ≤ 20A unless otherwise specified

Parameter	Min.	Typ.	Max.	Units	Notes & Conditions
ABSOLUTE MAXIMUM RATINGS					
Input Voltage					
Continuous	-80		+80	V	
Transient (≤ 1 s)	-100		100	V	
Isolation Voltage	-2250		2250	V dc	Input/output to common-mode pins
Output Current			25	A	
Operating Case Temperature	-40		100	°C	Baseplate temperature
Storage Case Temperature	-65		135	°C	
Lead Temperature (20 s)			300	°C	
RECOMMENDED OPERATING CONDITIONS					
Input Voltage					
Continuous	-80		+80	V	
Transient (≤ 1 s., Rs* = 0Ω)	-100		100	V	* Rs = Source Impedance
Output Current (continuous)	-20		20	A	
ELECTRICAL CHARACTERISTICS					
Output Voltage (continuous)	Vout = Vin - (Iin x Rdc)			V	
DC Resistance Rdc					total
Tcase = 25°C			25	mΩ	
Tcase = 100°C			32	mΩ	
Power Dissipation					20A output current
Tcase = 25°C			10	W	
Tcase = 100°C			13	W	
Total Differential-Mode Capacitance		80		μF	Measured across input or output pins
Total Common-Mode Capacitance		0.15		μF	Measured between any pin and common-mode pins
Bulk Capacitor		60		μF	
Damping Resistor		0.2		Ω	
Noise Attenuation	TBD				
Isolation Resistance	100			mΩ	Any pin to common-mode pins
RELIABILITY CHARACTERISTICS					
Calculated MTBF (Telcordia) TR-NWT-000332		TBD		10 ⁶ Hrs.	80% load, 200LFM, 40°C Ta
Calculated MTBF (MIL-217) MIL-HDBK-217F		TBD		10 ⁶ Hrs.	80% load, 200LFM, 40°C Ta
Field Demonstrated MTBF		TBD		10 ⁶ Hrs.	See our website for details
WEIGHT CHARACTERISTICS					
Device Weight		3.53/100		oz/g	

BASIC OPERATION AND FEATURES

This module is a multi-stage differential-mode and common-mode passive EMI filter designed to interface a power source with one or more SynQor dc-dc converters (or other loads that create EMI). Each stage of this filter is well damped to avoid resonances and oscillations, and only X7R multi-layer ceramic capacitors are used.

This InQor EMI filter includes a large bulk capacitor with a series damping resistor to correct for the unstabilizing effect of a converter's negative input resistance. A white paper discussing this negative input resistance and the need for corrective damping can be found on the SynQor website (see Input System Instability application note).

A typical application would place the InQor filter close to the input of the dc-dc converter. The Input common-mode pin would be connected to the chassis ground that is common with the system input line filter or other earthed point used for EMI measurement. The output common-mode pin would be connected to the output ground or plane of the power converters with as low inductance a path as possible. There are no connections to the metal baseplate, which may also be connected to the chassis ground if desired.

Do not connect the outputs of multiple InQor filters in parallel. Connecting filters in this manner may result in slightly unequal currents to flow in the positive and return paths of each filter. These unequal currents may cause the internal common-mode chokes to saturate and thus cause degraded common-mode rejection performance.

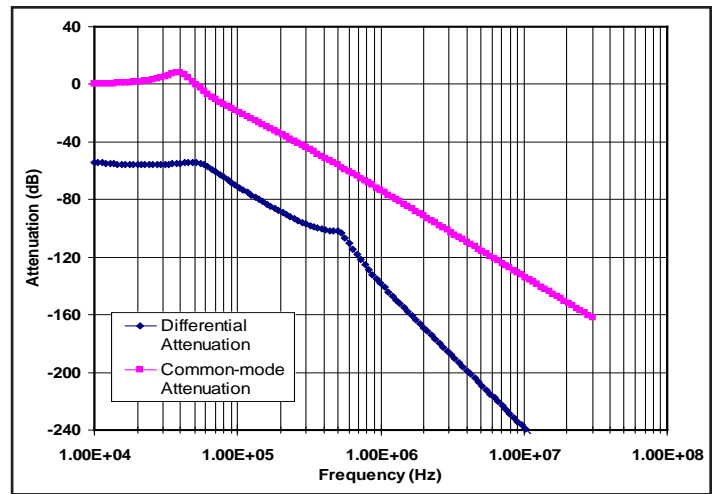

Figure 1: Typical Common Mode and Differential Mode Attenuation provided by the filter as a function of frequency, both input lines are connected to chassis ground through 50Ω resistors.

Standards & Qualification Testing

Parameter	Notes & Conditions
STANDARDS COMPLIANCE	
UL/cUL 60950-1	File # E194341, Basic insulation
EN60950-1	Certified by TUV
Needle Flame Test (IEC 695-2-2)	Test on entire assembly; board & plastic components UL94V-0 compliant
IEC 61000-4-2	ESD test, 8 kV - NP, 15 kV air - NP (Normal Performance)

Note: An external 35A input fuse must always be used to meet these safety requirements. Contact SynQor for official safety certificates on new releases or download from the SynQor website.

Parameter	# Units	Test Conditions
QUALIFICATION TESTING		
Life Test	32	95% rated Vin and load, units at derating point, 1000 hours
Vibration	5	10-55 Hz sweep, 0.060" total excursion, 1 min./sweep, 120 sweeps for 3 axis
Mechanical Shock	5	100g minimum, 2 drops in x and y axis, 1 drop in z axis
Temperature Cycling	10	-40 °C to 100 °C, unit temp. ramp 15 °C/min., 500 cycles
Power/Thermal Cycling	5	Toperating = min to max, Vin = min to max, full load, 100 cycles
Design Marginality	5	Tmin-10 °C to Tmax+10 °C, 5 °C steps, Vin = min to max, 0-105% load
Humidity	5	85 °C, 85% RH, 1000 hours, continuous Vin applied except 5 min/day
Solderability	15 pins	MIL-STD-883, method 2003

Mechanical Drawing

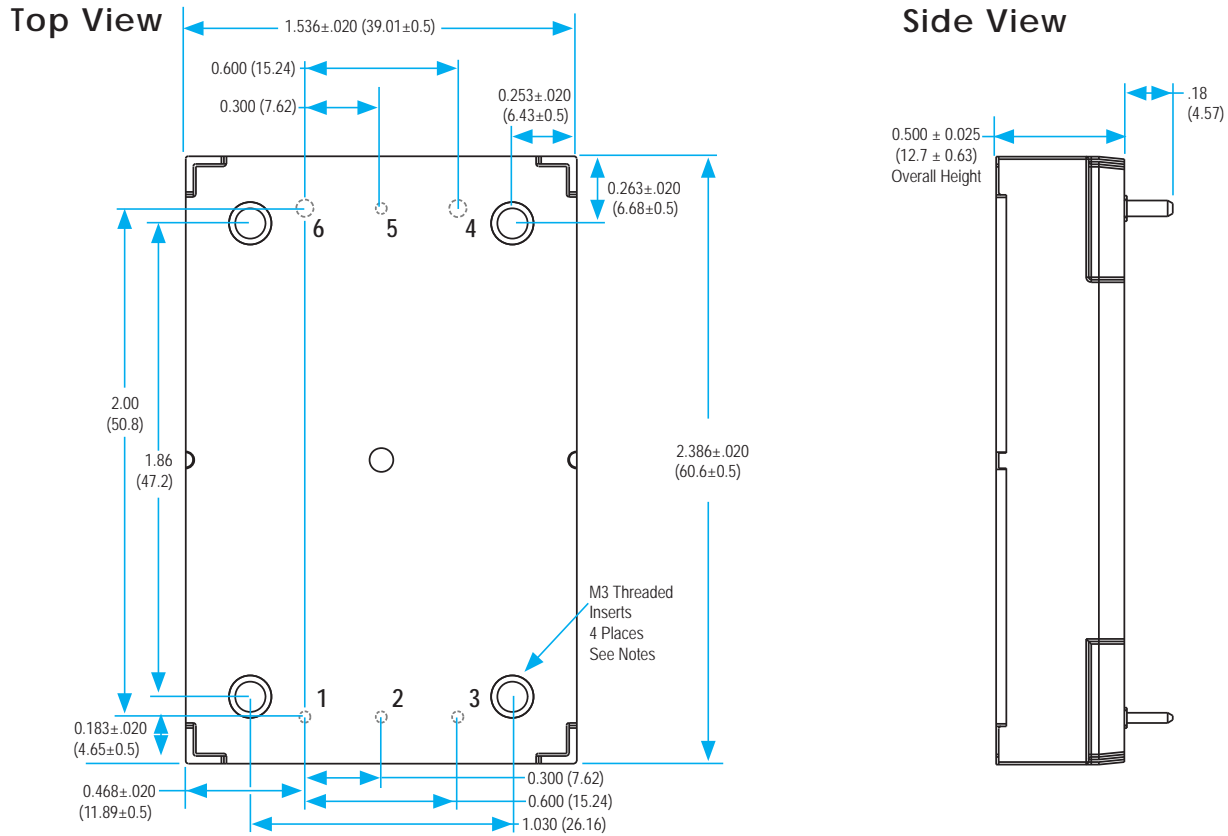

NOTES

- 1) Pins 1-3 & 5 are 0.040" (1.02 mm) diameter with 0.080" (2.03 mm) diameter standoff shoulders.
- 2) Pins 4 & 6 are 0.062" (1.57 mm) diameter with 0.100" (2.54 mm) diameter standoff shoulders.
- 3) Recommended pin length is 0.03" (0.76 mm) greater than the PCB thickness.
- 4) All Pins: Material - Copper alloy
Finish - Matte tin over nickel plate
- 5) M3 screws used to bolt unit's baseplate to other surfaces such as heatsink must not exceed 0.100" (2.54mm) depth below the surface of the baseplate.
- 6) Applied torque per screw should not exceed 6in-lb. (0.7 Nm).
- 7) Baseplate flatness tolerance is 0.004" (.10 mm) TIR for surface.
- 8) All dimensions in inches (mm)
Tolerances: x.xx +/-0.02 in. (x.x +/-0.5 mm)
x.xxx +/-0.010 in. (x.xx +/-0.25 mm)
- 9) Weight: 3.53 oz (100 g) typical
- 10) Workmanship: Meets or exceeds current IPC-A-610 Class II

PIN DESIGNATIONS

Pin No.	Name	Function
1	Vin (+)	Positive input voltage
2	Com In	Common-mode input
3	Vin (-)	Negative input voltage
4	Vout (-)	Negative output voltage
5	Com Out	Common-mode output
6	Vout (+)	Positive output voltage



Technical Specification

IQ080PFQTx20

APPLICATION NOTES

A variety of application notes and technical white papers can be downloaded in pdf format from our website.

RoHS Compliance: The EU led RoHS (Restriction of Hazardous Substances) Directive bans the use of Lead, Cadmium, Hexavalent Chromium, Mercury, Polybrominated Biphenyls (PBB), and Polybrominated Diphenyl Ether (PBDE) in Electrical and Electronic Equipment. This SynQor product is 6/6 RoHS compliant. For more information please refer to SynQor's RoHS addendum available at our [RoHS Compliance / Lead Free Initiative web page](#) or e-mail us at rohs@synqor.com.

PATENTS

SynQor holds the following U.S. patents, one or more of which apply to each product listed in this brochure. Additional patent applications may be pending or filed in the future.

5,999,417	6,222,742	6,545,890	6,577,109	6,594,159
6,731,520	6,894,468	6,896,526	6,927,987	7,050,309
7,072,190	7,085,146	7,119,524	7,269,034	7,272,021
7,272,023	7,558,083	7,564,702		

ORDERING INFORMATION

The tables below show the valid model numbers and ordering options the filters in this product family. When ordering SynQor filters, please ensure that you use the complete 15 character part number consisting of the 12 character base part number and the additional 3 characters for options. A "-G" suffix indicates the product is 6/6 RoHS compliant.

Model Number	Continuous Input Voltage	Max Output Current
IQ080PFQTw20SRS-G	-80 to +80V	20A

The following options must be included in place of the **wxyz** spaces in the model numbers listed above.

Options Description: wxyz			
Thermal Design	Enable Logic	Pin Style	Feature Set
C - Encased V - Encased with Flange	N - Negative	R - 0.180"	S - Standard

Not all combinations make valid part numbers, please contact SynQor for availability. See the [Product Summary web page](#) for more options.

Contact SynQor for further information:

Phone: 978-849-0600
Toll Free: 888-567-9596
Fax: 978-849-0602
E-mail: power@synqor.com
Web: www.synqor.com
Address: 155 Swanson Road
 Boxborough, MA 01719
 USA

Warranty

SynQor offers a two (2) year limited warranty. Complete warranty information is listed on our website or is available upon request from SynQor.

Information furnished by SynQor is believed to be accurate and reliable. However, no responsibility is assumed by SynQor for its use, nor for any infringements of patents or other rights of third parties which may result from its use. No license is granted by implication or otherwise under any patent or patent rights of SynQor.